

Reg No.: \_\_\_\_\_

Name: \_\_\_\_\_

**APJ ABDUL KALAM TECHNOLOGICAL UNIVERSITY**  
SEVENTH SEMESTER B.TECH DEGREE EXAMINATION(R&S), DECEMBER 2019

**Course Code: EC409**

**Course Name: CONTROL SYSTEMS**

Max. Marks: 100

Duration: 3 Hours

Note: Provide normal and semi log graph sheet

**PART A**

*Answer any two full questions, each carries 15 marks.*

Marks

- 1 a) Find the overall gain  $C(s)/R(s)$  for the signal flow graph shown using Mason's gain equation. (8)

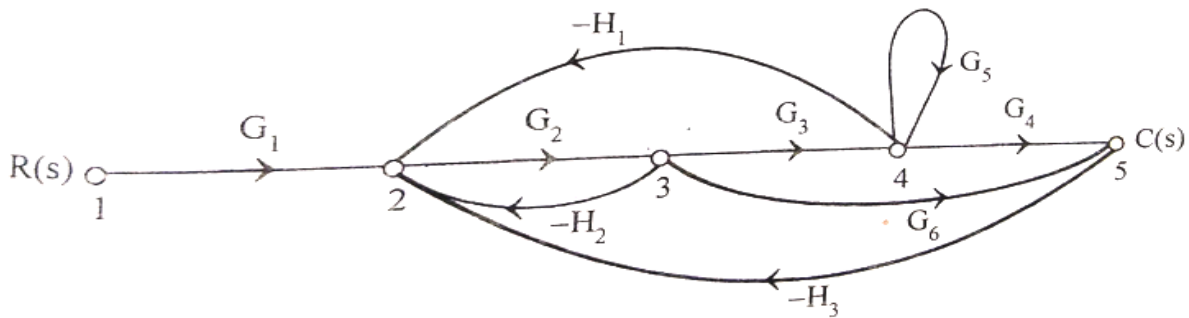

- b) Determine the transfer function  $X_1(s)/F(s)$  for the system shown below. (7)

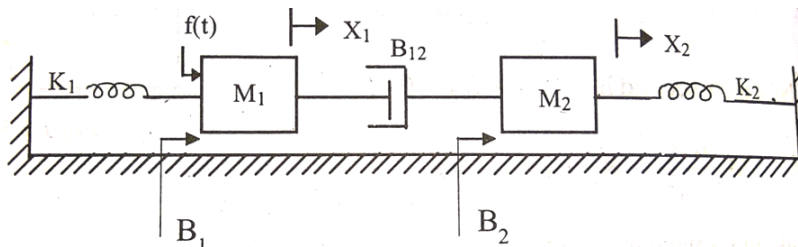

- 2 a) The open loop transfer function of a servo system with unity feedback is (7)

$$G(s) = \frac{10}{s(0.1s+1)}$$

Evaluate the static error constants of the system. Obtain the steady state

error of the system when subjected to an input given by

$$r(t) = a_0 + a_1t + a_2t^2/2.$$

- b) Derive an expression for time response of second order under damped system to step input. (8)

- 3 a) The unity feedback system is characterised by an open loop transfer function  $G(s) =$  (7)

$$\frac{K}{s(s+10)}$$

Determine the gain K so that the system will have a damping ratio of 0.5 for this

value of K. Determine the settling time, peak overshoot, rise time and peak time for a unit step input.

- b) Obtain the closed loop transfer function  $C(s)/R(s)$  of the system using block reduction technique. (8)

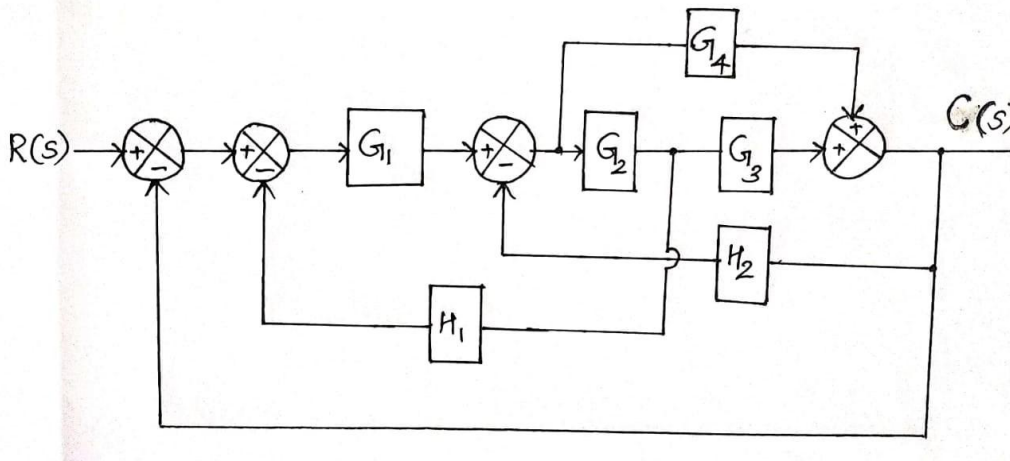

### PART B

*Answer any two full questions, each carries 15 marks.*

- 4 a) Sketch the root locus for the unity feedback system whose open loop transfer function is (9)

$$G(s)H(s) = \frac{K}{s(s+4)(s^2+4s+20)}$$

- b) The characteristic polynomial of a system is  $s^7+9s^6+24s^5+24s^4+24s^3+24s^2+23s+15=0$ . (6)

Determine the location of roots on s-plane and hence comment on the stability of the system using Routh-Hurwitz criterion.

- 5 a) Sketch the Bode diagram for the following transfer function. (10)

$$G(s) = \frac{75(1+0.2s)}{s(s^2+16s+100)}$$

Determine gain margin and phase margin.

- b) State and explain Nyquist stability criteria (5)

- 6 a) Explain frequency domain specifications (6)

- b) Describe the design procedure for a lag compensator. (9)

### PART C

*Answer any two full questions, each carries 20 marks.*

- 7 a) Determine the controllability and observability of the given system. (5)

$$\begin{bmatrix} \dot{x} \\ \dot{y} \end{bmatrix} = \begin{bmatrix} -0.5 & 0 \\ 0 & -2 \end{bmatrix} \begin{bmatrix} x \\ y \end{bmatrix} + \begin{bmatrix} 0 \\ 1 \end{bmatrix} u(t)$$

$$y(t) = [0 \ 1] \begin{bmatrix} x \\ y \end{bmatrix}$$

b) A system is described by the transfer function  $\frac{Y(s)}{U(s)} = \frac{10(s+4)}{s(s+2)(s+3)}$ . Find the state and output equations of the system. (10)

c) Obtain the state space representation of the electrical system. (5)

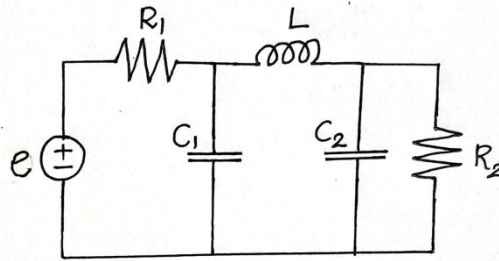

8 a) The input-output relation of a sampled control system is described by the equation  $c(k+2) + 3c(k+1) + 4c(k) = r(k+1) - r(k)$ . Determine the z transfer function. (5)

b) Determine the stability of a sampled data control system having the following characteristic polynomial (10)

$$z^4 - 1.7z^3 + 1.04z^2 - 0.268z + 0.024 = 0$$

c) Derive the transfer function of a zero order hold circuit. (5)

9 a) List out the properties of state transition matrix. Obtain the state transition matrix of (10)

$$A = \begin{bmatrix} 2 & 0 \\ -1 & 2 \end{bmatrix}$$

b) Determine the pulse transfer function for the system represented by the block diagram. (10)

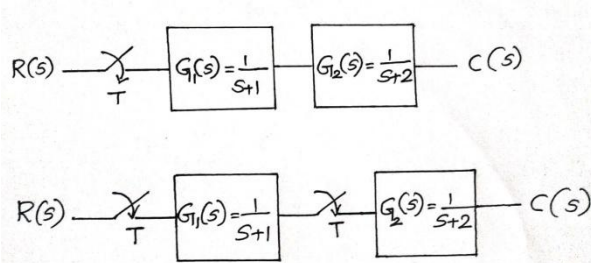

\*\*\*\*